



AGRICULTURAL MECHANIZATION DEVELOPMENT PROGRAM

**Institute of Agricultural Engineering
College of Engineering and Agro-Industrial Technology
University of the Philippines Los Baños
College, Laguna, Philippines**

UPLB HAND TRACTOR (with steering clutch)



For more information, contact:

**The Program Manager
Agricultural Mechanization Development Program
Institute of Agricultural Engineering
College of Engineering and Agro-industrial Technology
University of the Philippines Los Baños
College, 4031 Laguna, Philippines
Tel. No. (049)536-2686, Telefax No: (049)536-3606
Email: amdpu@uplb.edu.ph or amdpu@uplb.edu.ph
Website: <http://iae.uplb.edu.ph/index.php/amdp>**

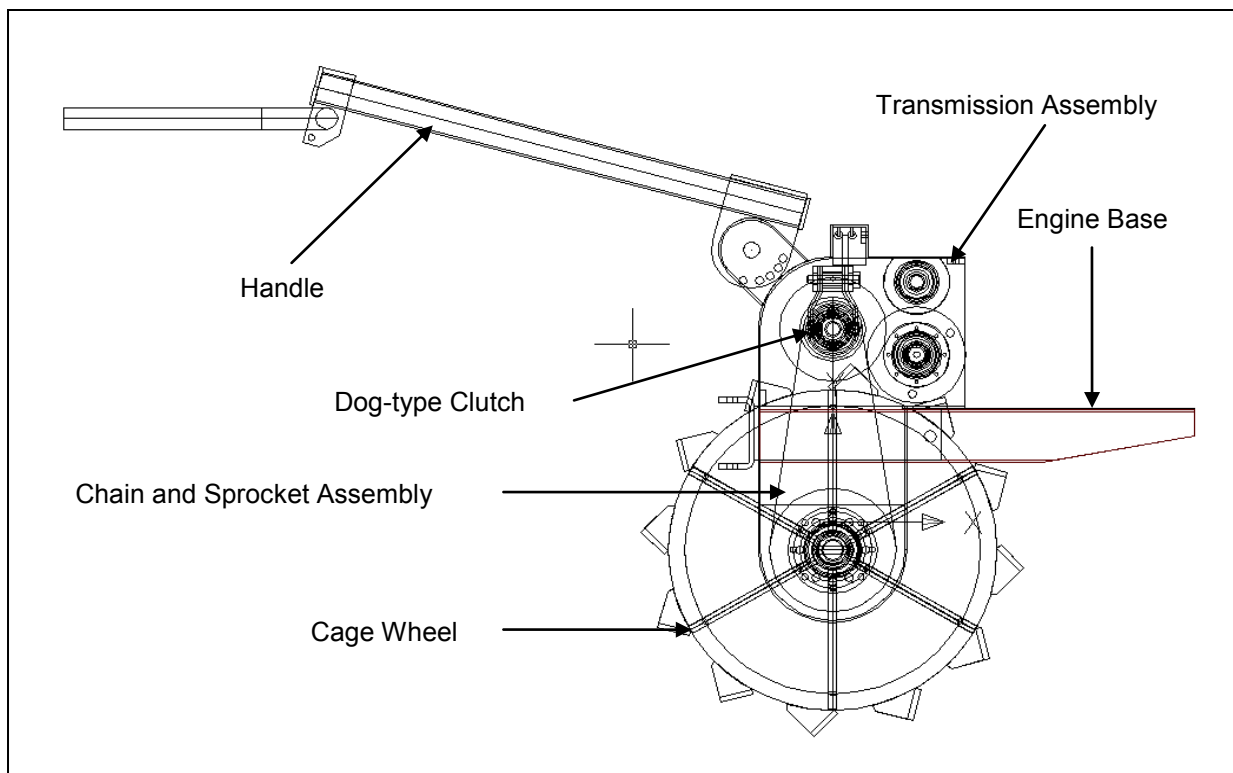

FEATURES:

- The steering mechanism is simple in design and can be fabricated by ordinary machine shops
- Made of locally available fabrication materials
- Affordable
- Durable
- Can be operated in stony field condition
- Easy to maneuver due to the presence of steering mechanism

SPECIFICATIONS:

Type of Machine:	Single split-type axle, pull type hand tractor
Dimensions (mm):	
Length:	2050
Width:	1045
Height:	1000
Weight:	141.0 kg (without engine)
Steering Mechanism:	Idler and dog type steering clutch (clutch attached to drive sprockets)
Power Transmission:	Belt, pulley and chain and sprocket
Power source:	7.46 kW (10 Hp) engine
Number of operator:	one person
Plowing attachment:	Single-bottom moldboard plow